



DESCRIPTION

The Badger Meter® Turbo/Butterfly Valve water batching system is designed to control and measure the water batching process in concrete batch plants, block plants, pre-stress concrete batch plants or wherever there is a need for water batching. Our reliable Industrial Turbine Meter, with either an unscaled pulse transmitter or an electronic scalable transmitter, combined with a solenoid-controlled air operated butterfly valve creates a water batching system that provides accurate and dependable service in all types of batch plant environments. The batching system can be specified with either a scaled pulse transmitter for use with the CB-20 Batch Controller for semi-automatic batching or an electronic scalable transmitter for use in fully automated plants.

The Turbo meter is compact in size and is easy to service without removing the meter from the lines. Available in four line sizes (2", 3", 4" and 6") for up to 2000 gpm (7570 lpm), the system provides a high level of accuracy over a wide flow range with a minimum of pressure loss. Its unique straight-through flow profile and ceramic bearing design optimize performance and accuracy.

The solenoid controlled air operated butterfly valve permits higher flows at lower pressure loss. The valve requires a 60 psi minimum air supply to operate. Included with the valve is a speed control to adjust the closing speed of the valve, which assists in the reduction of water hammer.

Transmitter Options

- Magneto resistive pulse transmitter
- Electronic scalable transmitter

CB-20 Batch Controller Options

- Remote mounted
- Meter mounted

OPERATION

The Badger Meter Industrial Turbine is a volumetric liquid flow meter which works on the time proven principle of a rotor turning at an angular velocity proportional to the fluid velocity through the turbine. The meter has straightening vanes and a nose cone in the inlet side that minimize upstream turbulence and direct the flow to the rotor effectively. The motion of the rotor is relayed to the meter's magneto resistive pulse transmitter or electronically scalable transmitter. The scalable transmitter can then be adjusted to produce the desired pulse rate.

The solenoid-controlled air operated butterfly valve is controlled by the water batch controller that receives the pulse output signal from the transmitter. When the batch command is received, the solenoid energizes and allows the butterfly valve to be opened by air pressure. When the amount of water for the initial batch has been dispensed, the controller de-energizes the solenoid and allows air pressure to close the butterfly valve. Using the speed control, the butterfly valve can be adjusted so that it closes slowly enough to reduce water hammer.

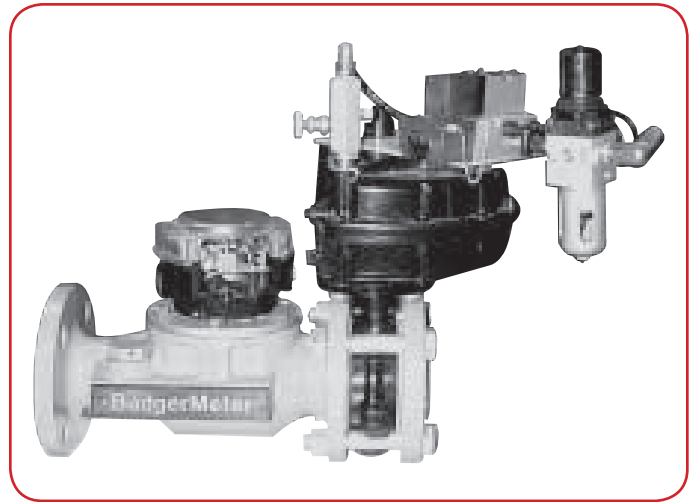

MATERIALS

Other materials are available upon request.

Meter

Housing Material	Cast Iron
O-Ring and Tetraseal	Buna N
Rotor & Nose Cone	Ryton
Bearings	Ceramic
Straightening Vanes	316 Stainless Steel
Head Gasket	Nitrile Binder

Valve

Body	Ductile Iron
Disc	Nickel Plated
Stem (upper and lower)	410 Stainless Steel
Seat and O-Ring	EPDM

FEATURES

- Long lasting ceramic bearings
- Simple in-line serviceability
- Low pressure loss
- Positive ON and OFF control fail-safe with power loss
- Helps reduce water hammer
- Easy (ON JOB) calibration without gears or special tools
- Complete tested assembly ready to install in line
- Manual override on 4-way solenoid valve

Product Data Sheet

DIMENSIONS

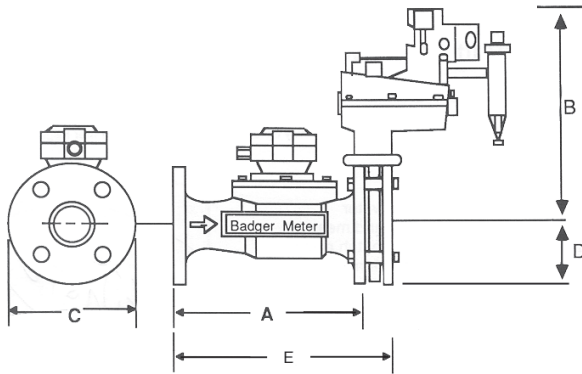

	2"	3"	4"	6"
A	10.00 in. (254 mm)	12.00 in. (305 mm)	14.00 in. (356 mm)	*
B	13.67 in. (347 mm)	13.67 in. (347 mm)	15.34 in. (390 mm)	*
C	6.00 in. (152 mm)	7.50 in. (191 mm)	9.00 in. (229 mm)	*
D	2.75 in. (70 mm)	3.50 in. (89 mm)	4.25 in. (108 mm)	*
E	12.75 in. (324 mm)	15.00 in. (381 mm)	17.12 in. (435 mm)	*
Est. Wt.	30...40 lb (14...18 kg)	40...50 lb (18...23 kg)	60...75 lb (27...34 kg)	100...125 lb (45...57 kg)

* Consult factory for 6".

SPECIFICATIONS

System

System Size	2"	3"	4"	6"
Accuracy ±0.5% @ indicated Flow Range	20...160 gpm (76...606 lpm)	60...350 gpm (227...1325 lpm)	100...1000 gpm (378...3785 lpm)	250...2000 gpm (946...7570 lpm)
Accuracy ±1.5% @ indicated Flow Range	8...200 (30...757 lpm)	10...450 gpm (38...1703 lpm)	25...1250 gpm (95...4732 lpm)	40...2500 gpm (151...9464 lpm)
Repeatability*	0.25%			
Temperature Range*	32...200° F (0...93° C)			
Minimum Operating Pressure	7 psi (0.5 bar)			
Maximum Operating Pressure	125 psi (8.6 bar)			

* Reading over full range tested with potable water at 60° F (16° C).

Flange Face Configurations: (ANSI Standards)

Flat Faced Flanges: 125 lb (57 kg) Cast Iron

Solenoid

Voltage	115V AC/60 Hz (Other voltages available upon request)
Power Consumption	0.29 Amp Inrush 0.18 Amp Holding 60...120 psi (4...8 bar)
Actuator Displacement	41 cu in./190° stroke

Meter

Meter Size	2"	3"	4"	6"
Accuracy	± 1.5%			
Repeatability*	± 0.25%			
Temperature Range**	32...250° F (0...121° C)			
Flow Range	8...160 gpm (30...606 lpm)	10...350 gpm (38...1325 lpm)	25...1000 gpm (95...3785 lpm)	40...2000 gpm (151...7570 lpm)
Minimum Operating Pressure	7 psi (0.5 bar)			
Maximum Operating Pressure	125 psi (8.6 bar)			

* Reading over full range tested with potable water at 60° F (16° C).

** Temperature rating is for meters with PFT 3-E transmitters. Other ratings are available.